

PRORIL

STAINLESS STEEL PUMPS

DEWATERING PUMPS

SEWAGE VORTEX PUMPS



60 Hz

STAINLESS STEEL PUMPS

DEWATERING & SEWAGE VORTEX

PRORIL stainless steel pumps consist of four dewatering pumps and two sewage pumps. They are available in 304 or 316 stainless steel.

These pumps are designed for handling clean water or screened wastewater, also applicable to the aquaculture industry with the use of the food-grade lubricant.

FEATURES

1 Watertight Cable Entry

The cable entry employs an anti-wicking block where each conductor is stripped and encapsulated in epoxy. This feature effectively prevents water from penetrating the motor chamber when the cable end is submerged or the cable sheath is damaged.

2 Top Discharge and Double Housing Design

Designed to construct a water jacket that provides maximum motor cooling effect for continuous operation at low water level, this feature forms the cylindrical and slim shape of the pump and enables the pump to be installed in confined spaces.

3 Motor Protector

The motor incorporates a circle thermal protector which protects against overheating and dry-run.

4 Submersible Motor

Air filled motor, housed in a watertight casing, conforms to Class F insulation.

5 C3 Ball Bearings and Hardened SS Shaft

High quality of C3 ball bearings and the well-balanced, hardened stainless steel shaft enhance stability during continuous pumping operations.

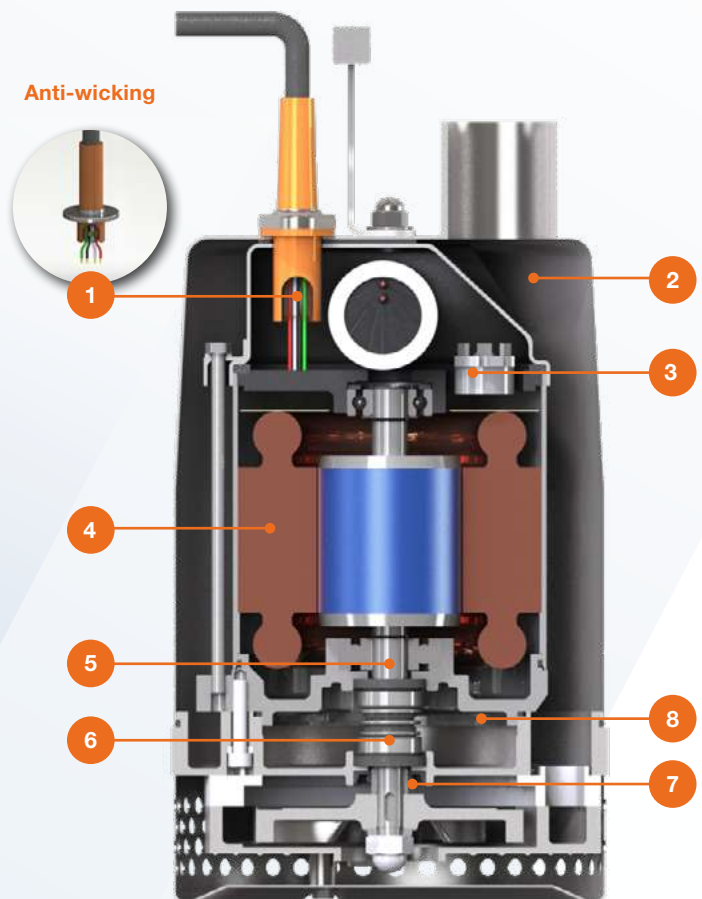

6 Double Mechanical Seals

Located in the oil chamber, the device is made of quality materials with highly wear-resistant silicon carbide in lower side that provides extra protection against leakage and dry-run.

7 Extra Protection for Mechanical Seals and Shaft

Lip seals and shaft sleeves are utilized for additional protection against wear.

8 Food Grade Lubricant

PRORIL adopts eco-friendly lubricant to minimize environmental impacts.



X-SMART

400 750



X-SMART	400	750
Outlet	2" (50mm)	2" (50mm)
Rated Output	0.5HP (0.4kW)	1HP (0.75kW)
Shaft Speed	3450 rpm	3450 rpm
Solid Passage	0.2" (5.5mm)	0.3" (7mm)
Height	13.1" (333mm)	14.2" (361mm)
Diameter	Ø7.1" (180mm)	Ø7.1" (180mm)
Weight	29 lbs (13kg)	31 lbs (14kg)

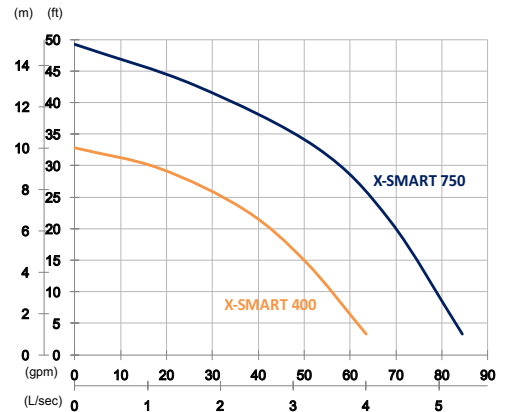

X-SMART

215 315



X-SMART	215	315
Outlet	2" (50mm)	3" (80mm)
Rated Output	2HP (1.5kW)	2HP (1.5kW)
Shaft Speed	3450 rpm	3450 rpm
Solid Passage	0.3" (7mm)	0.3" (7mm)
Height	17.7" (449mm)	17.7" (449mm)
Diameter	Ø7.3" (186mm)	Ø7.3" (186mm)
Weight	42 lbs (19kg)	42 lbs (19kg)

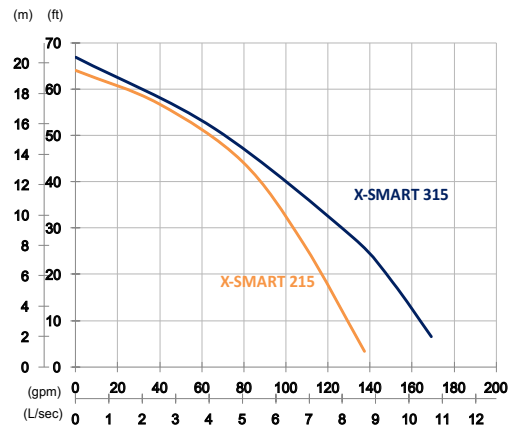

X-VOX

208 215



X-VOX	208	215
Outlet	2" (50mm)	2" (50mm)
Rated Output	1HP (0.75kW)	2HP (1.5kW)
Shaft Speed	3450 rpm	3450 rpm
Solid Passage	1.6" (40mm)	1.5" (37mm)
Height	16.3" (415mm)	17.5" (445mm)
Diameter	Ø9.2" (233mm)	Ø9.2" (233mm)
Weight	26 lbs (12kg)	33 lbs (15kg)

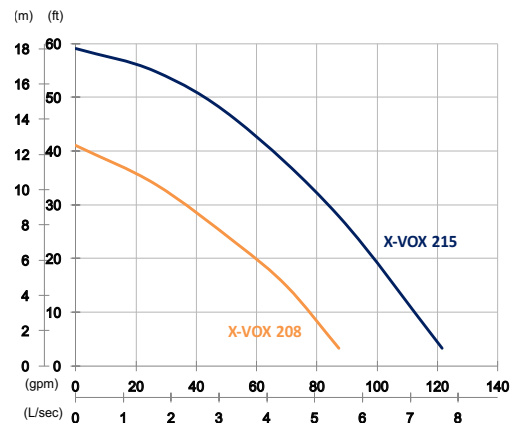



WWW.PRORIL.COM

PRORIL PUMPS CORPORATION

SS-60-108001